

Euromat 64 S/L

The in-store baking oven,
that is future-oriented
even in the future

*** Cleaning made easy:**

The automatic ProClean cleaning system dissolves
even the most stubborn dirt in the baking chamber



THE IN-STORE BAKING OVEN

- **BAKING CHAMBER:** Rounded corners and removable interior and exterior parts make it easy to clean. The side-ways slide-in ensures easy handling
- **INDIRECT LIGHTING:** Creates an attractive backdrop for your bakery products. The halogen lights in the door frame can be easily exchanged without tools
- **FLOW CONDITIONS:** Controlled intelligently with 8 fan speeds and a right/left rotation fan for a consistent baking result in the convection oven
- **STEAMING:** Fast steam generation with the correct steam quantity for every bake
- **CLEANING:** ProClean automatic cleaning system for efficient operation. The outside of the door can be opened easily without tools for a transparent view
- **THERMODYN GLAZING:** Reduced radiant heat, a cool outer door and less energy consumption ensure lower costs and higher safety
- **USB PORT:** Direct playback of baking programs, logos and reading of log files
- **WNET:** Networking of your ovens across every store

OPTIONS

Cleaning	ProClean/LiquidClean/Combination of ProClean + LiquidClean
Modular construction	Capacity expansion possible at any time
Door	Opens to right/left, safety locking
Steaming unit	Pipe steaming, passive cascade
Design	Nostalgic or Stainless Steel

COMBINATION OPTIONS

- With all Euromat 64 in-store baking ovens
- Ebo 64 deck oven
- Steam reducer with fully-automatically controlled steam condenser
- Support with castors or pedestal
- Hygiene prover with castors or pedestal
- Storage rack
- Loading system

CONTROL UNIT

IS 600 E



- Rotary knob
- Colored pictograms (display of pictograms + text)
- 32 languages and symbols
- Ring tone playable as .wav file
- Time settings to the nearest second
- Slide-in based program handling
- Easy manual programming or via USB port
- 200 baking programs each with 20 steps
- Pre-programmable auto start
- 8 fan speed

NETWORKING

WNET



- Networks all WIESHEU in-store baking ovens with head office
- Online platform enables central set up of baking programs
- Online sending, receiving and administration of baking program
- Read-outs of consumption and BDE data
- Play back of logos and ring tones
- Compiles analyses of individual devices, stores and groups

TECHNICAL DETAILS

	EUROMAT 64 S Item No. 2500	EUROMAT 64 L Item No. 2600
Number of layers of trays x tray dimensions (mm)	4/5 x 600 x 400	8/10 x 600 x 400
Tray distance (mm)	100/80	100/80
External dimensions (W x D x H in mm) with ProClean	930 x 980 x 575 930 x 980 x 695	930 x 980 x 975 930 x 980 x 1095
Power requirements		
Mains	400 V 3/N/PE	400 V 3/N/PE
Frequency	50 Hz	50 Hz
Power consumption	13.6 A	27.0 A
Connected load	9.4 kW	18.7 kW
Weight (kg)		
with cascade steaming	120	180
with pipe steaming	110	160
Steaming type		
Cascade (passive)	Option	Option
Pipe steaming	Series	Series
Water Pressure (kPA)	150 – 600	150 – 600

Capacity of baking product per tray (e.g. slit rolls): 15 with fresh dough, 18 with pre-baked dough pieces

TECHNICAL DRAWINGS

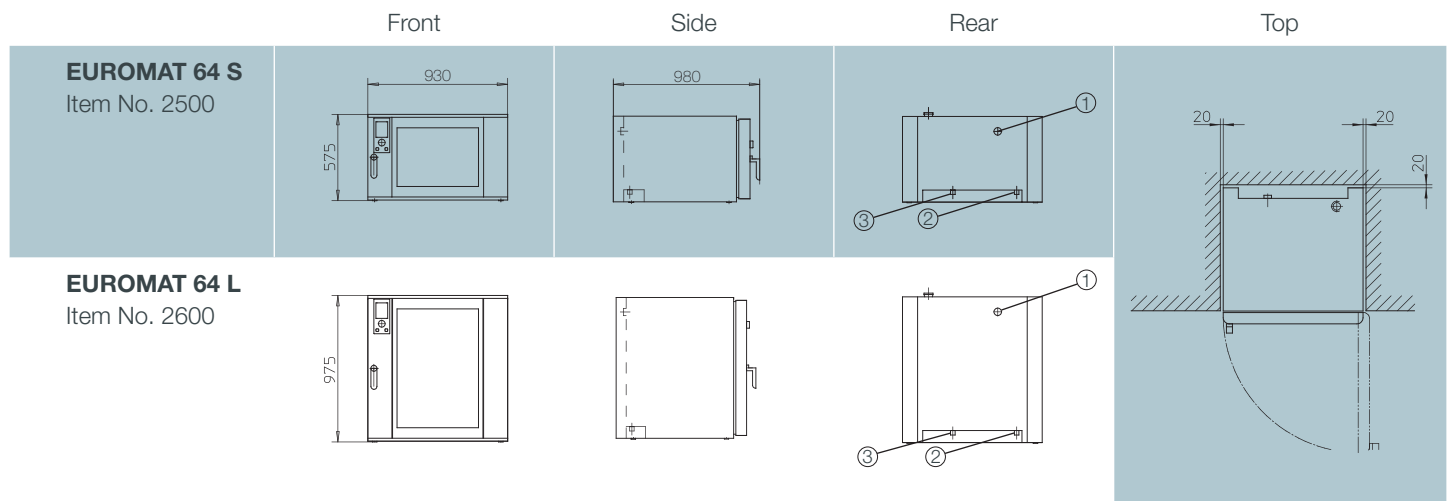

1 Outlet Air 50 mm 2 Power Connection 3 Water Connection 3/4"



Pipe steaming

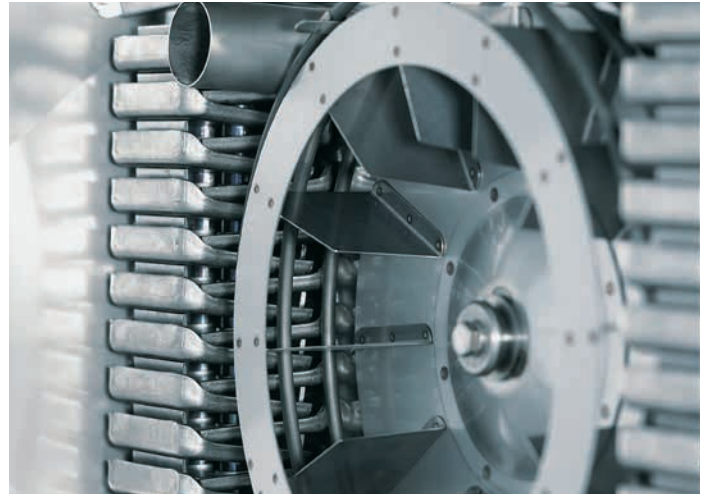

Cascade steaming



Baking chamber



Nostalgic design



Hinged glass front plate



ProClean automatic cleaning system